

Front View: Circuit Board Layout

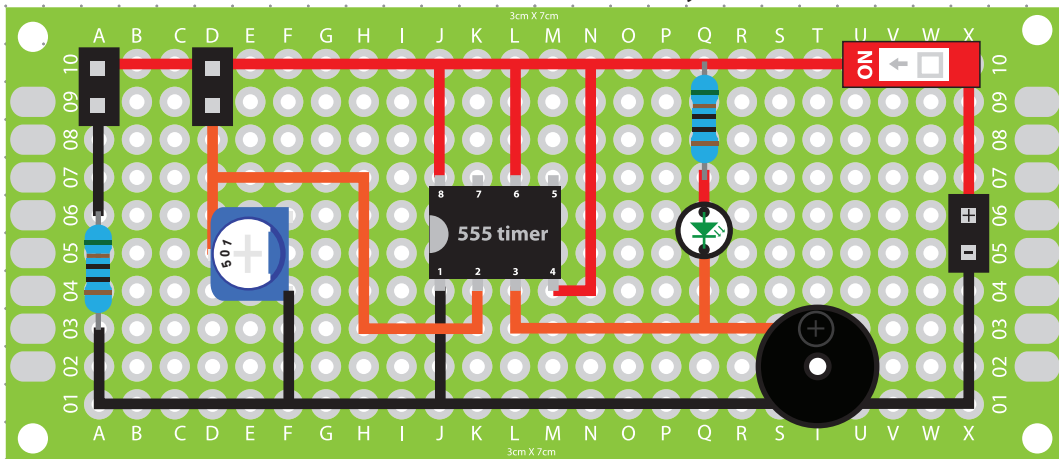

Back View: Circuit Board Layout

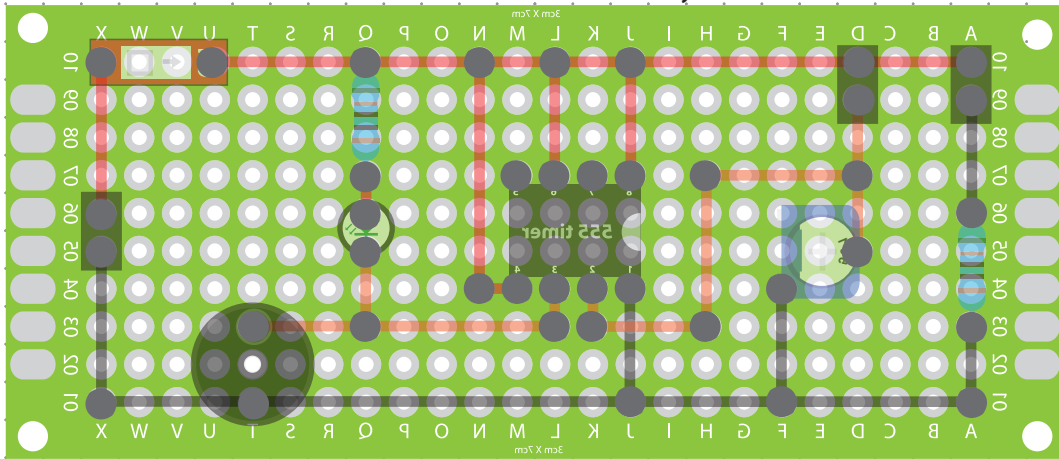

Electrical Schematics

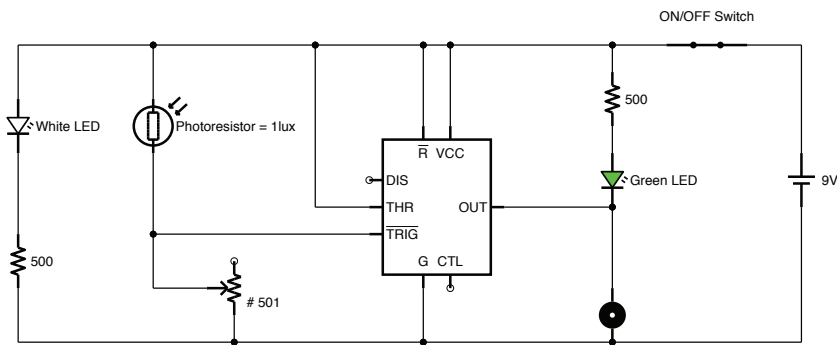

Materials:

- 1 3x7cm Circuit Board
- 2 Bridge Pins
- 2 2-Pin Female Bridges
- 1 ON/OFF Switch
- 1 555 Timer IC
- 2 500 Resistors
- 1 #501 variable resistor
- 1 White LED
- 1 Green LED
- 1 Photoresistor

Project: Security Alarm

Client:

5mm Dot Grid

Designer: Scott A. Campbell

Builder:

Scale:

2:1