

Front View: Circuit Board Layout

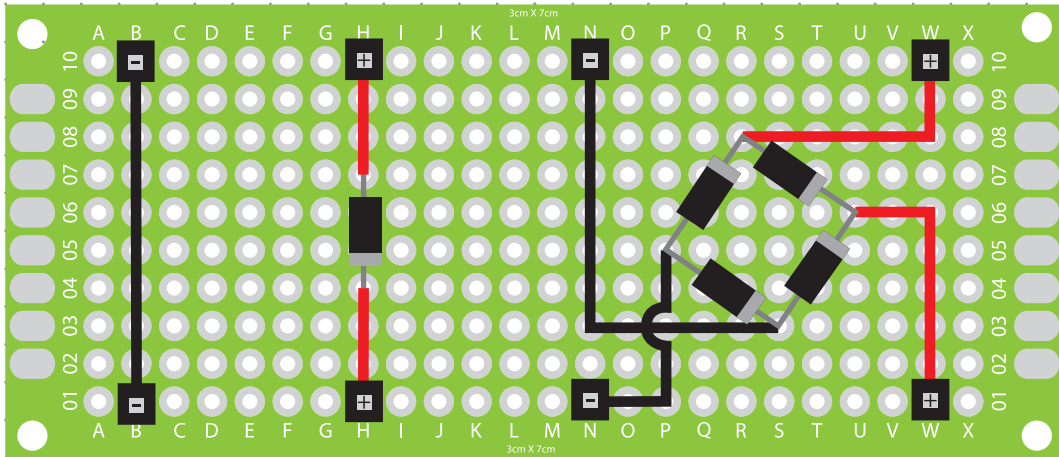

Back View: Circuit Board Layout

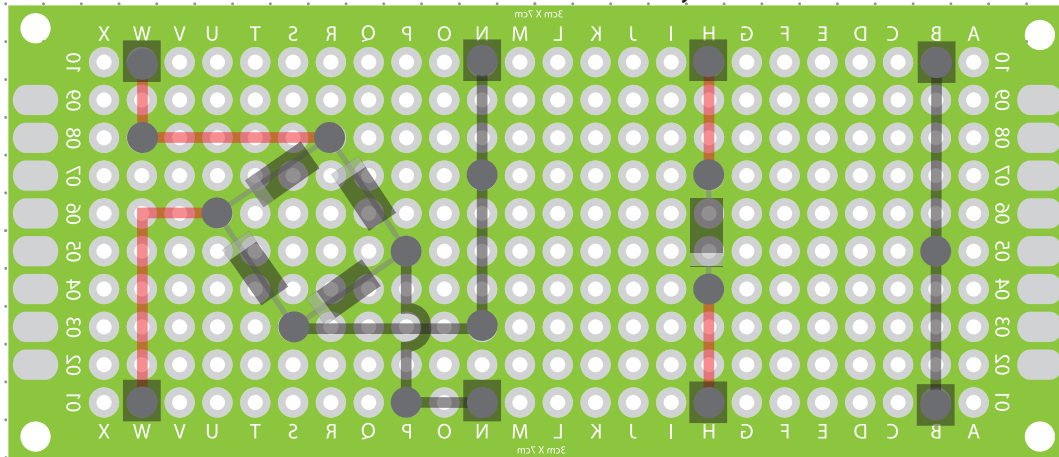

Electrical Schematics

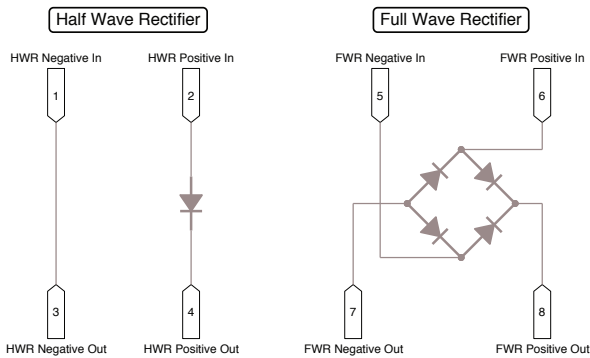

Materials:

- 1 3x7cm Circuit Board
- 5 Diodes N4001 (1.0A/50V)
- 6 Bridge Connectors
- 1 10cm Length of Red Wire
- 1 10cm Length of Black Wire

Project: Rectifier Experiment

Client:

5mm Dot Grid

Designer: Scott A. Campbell

Builder:

Scale:

2:1