

Front View: Circuit Board Layout

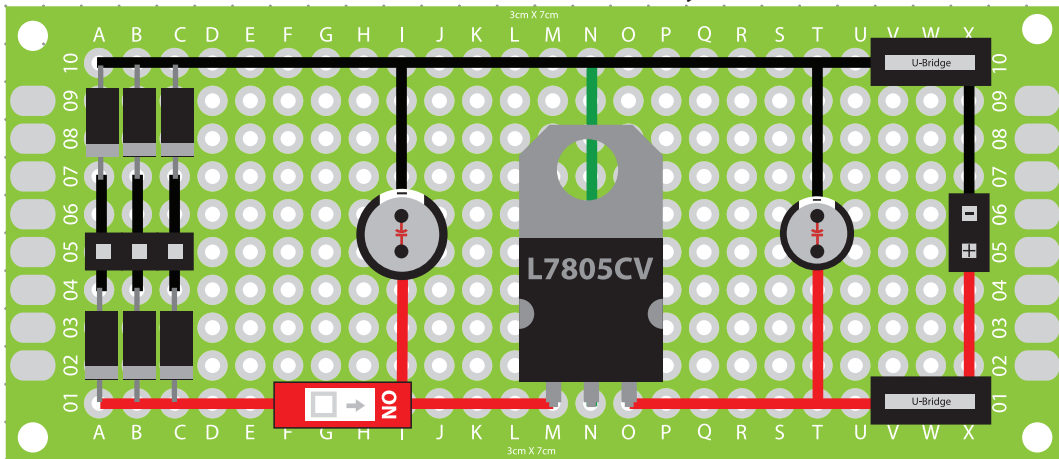

Back View: Circuit Board Layout

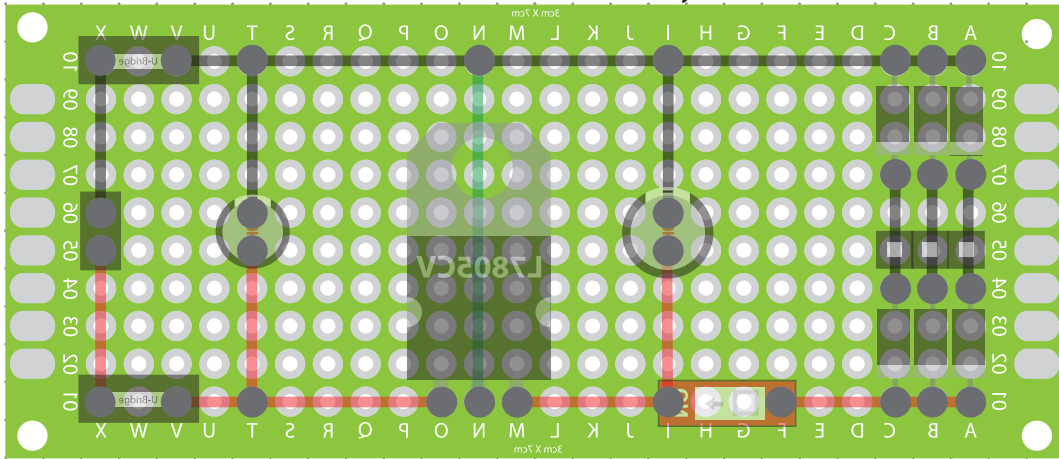

Electrical Schematics

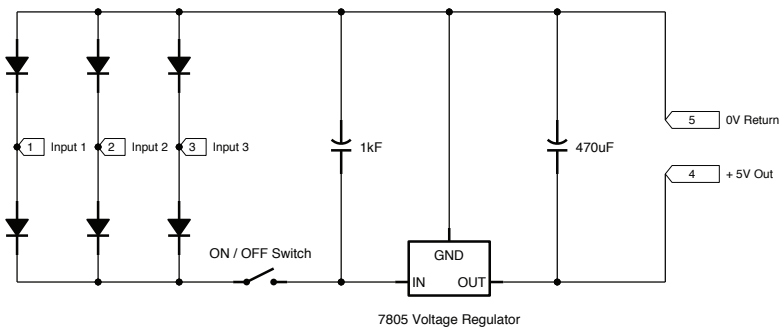

Materials:

- 1 3x7cm Circuit Board
- 6 Diodes N4001 (1.0A/50V)
- 5 Pin Type Bridge Conectors
- 2 U-Type Bridge Conectors
- 1 1000uF 25V Capacitor
- 1 470uF 25V Capacitor
- 1 30cm Length of Red Wire
- 1 30cm Length of Black Wire

Project: Green Industries Phase Rectifier

Client:

5mm Dot Grid

Designer: Scott A. Campbell

Builder:

Scale:

2:1