

Front View: Circuit Board Layout

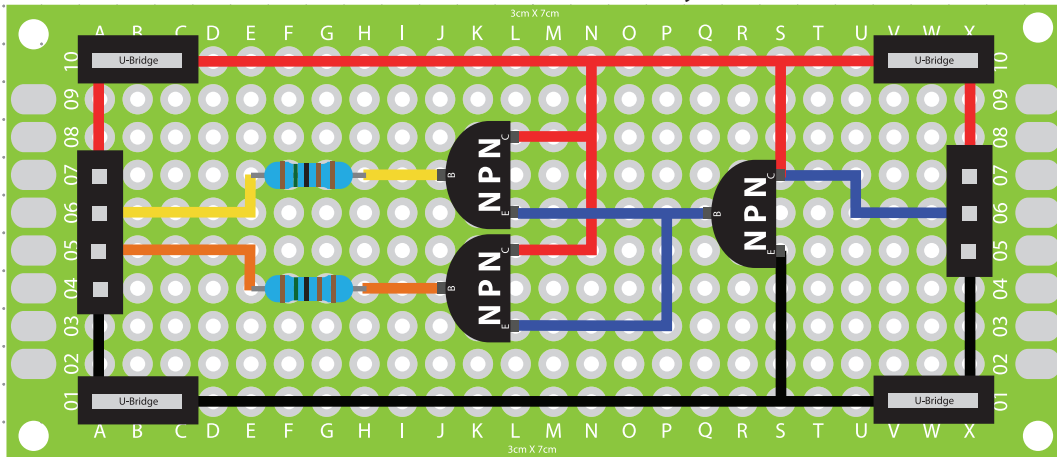

Back View: Circuit Board Layout

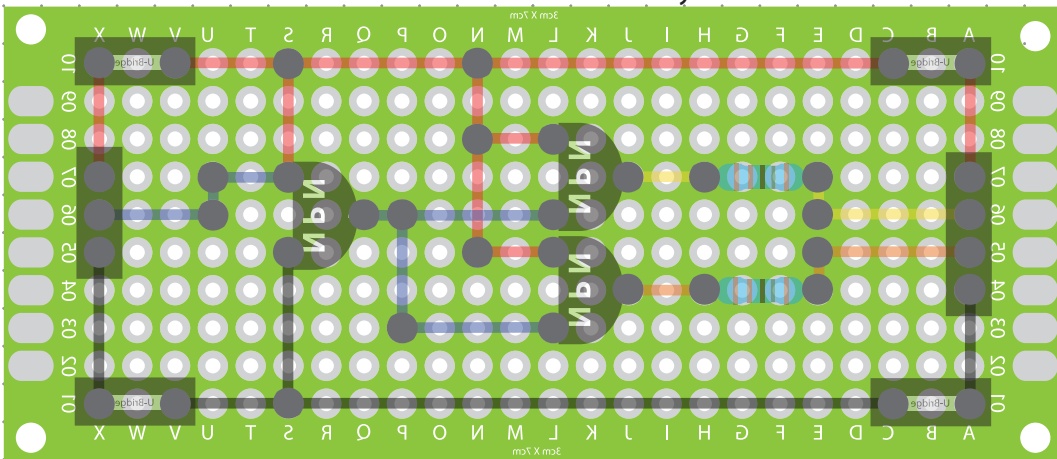

Electrical Schematics

Materials:

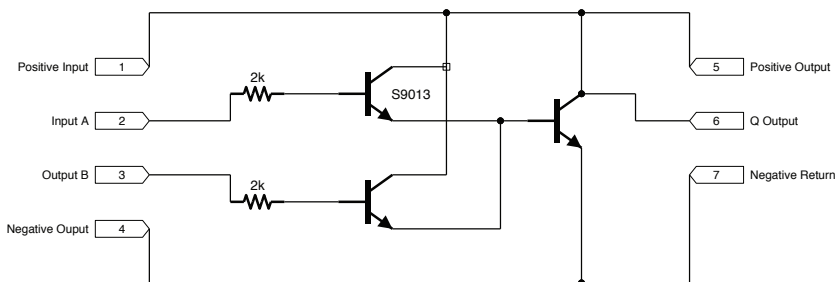

- 1 3x7cm Circuit Board
- 4 Bridge Pins
- 4 U-Bridge Connectors
- 1 3-Pin Female Bridge
- 3 S9013 NPN Transistors
- 2 2K Resistors
- 1 100cm Assorted Wires

Project: Compound NOR Gate	Client:	5mm Dot Grid Scale: 2:1
Designer: Scott A. Campbell	Builder:	