

Front View: Circuit Board Layout

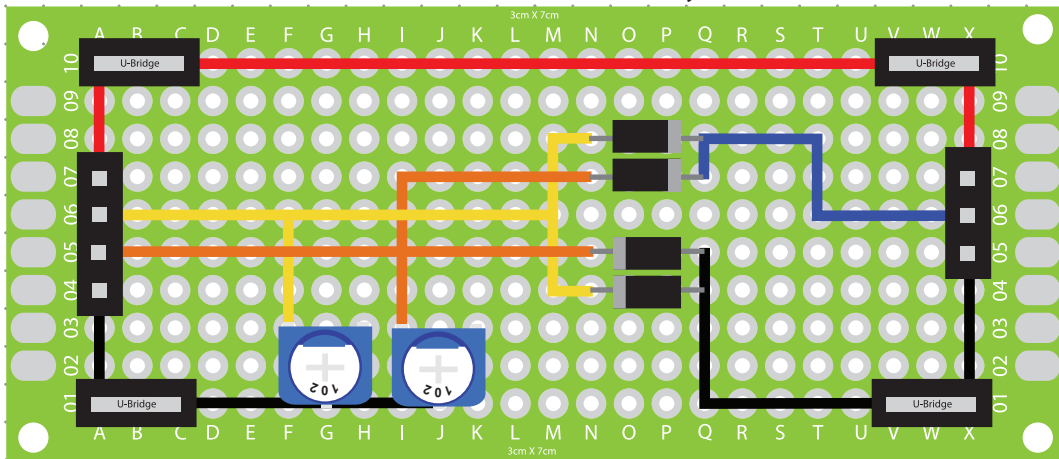

Back View: Circuit Board Layout

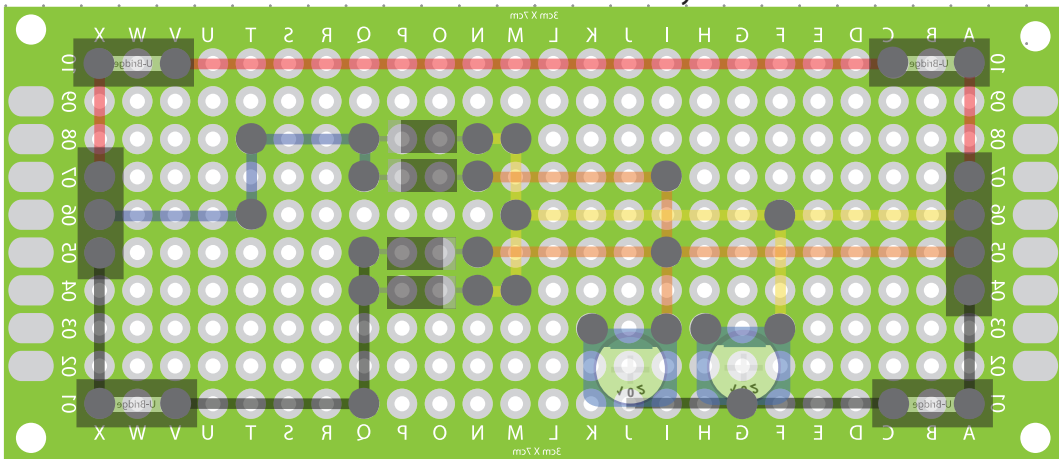

Electrical Schematics

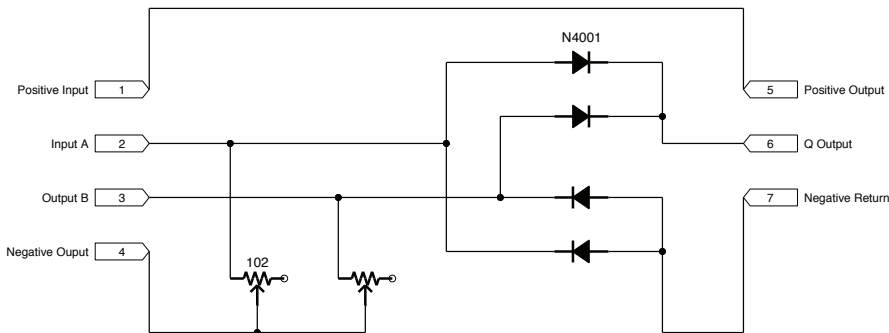

Materials:

- 1 3x7cm Circuit Board
- 4 Bridge Pins
- 4 U-Bridge Connectors
- 1 3-Pin Female Bridge
- 4 N4001 Diodes
- 2 #102 Variable Resistor (1K)
- 1 100cm Assorted Wires

Project: Advanced Diode XOR Gate

Client:

5mm Dot Grid

Designer: Scott A. Campbell

Builder:

Scale:

2:1