

Front View: Circuit Board Layout

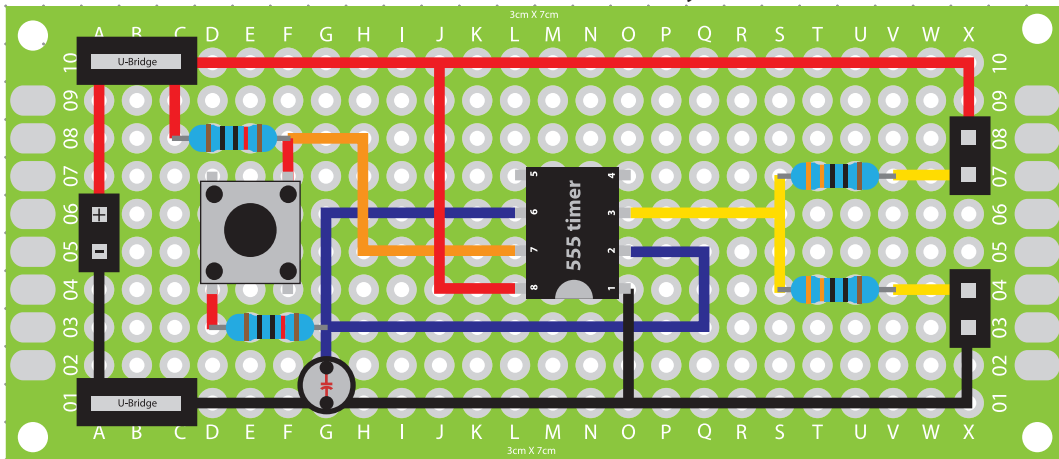

Back View: Circuit Board Layout

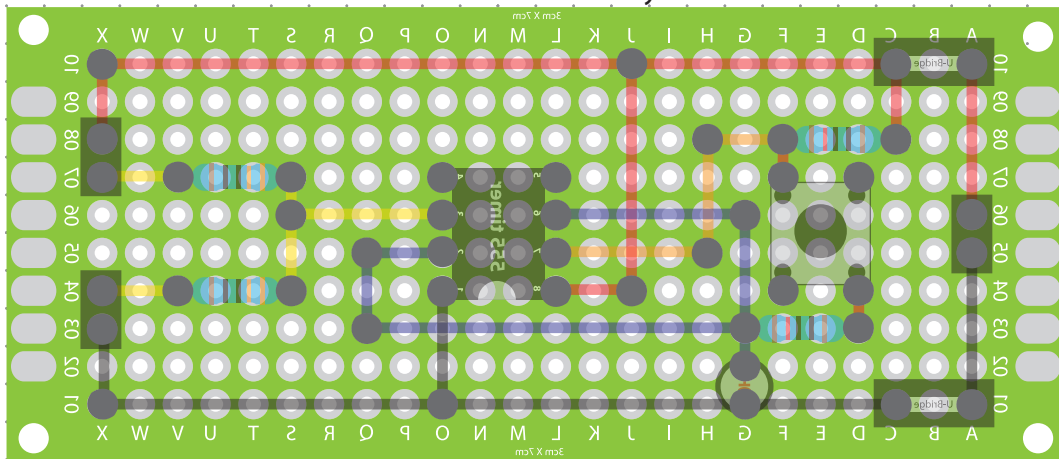

Electrical Schematics

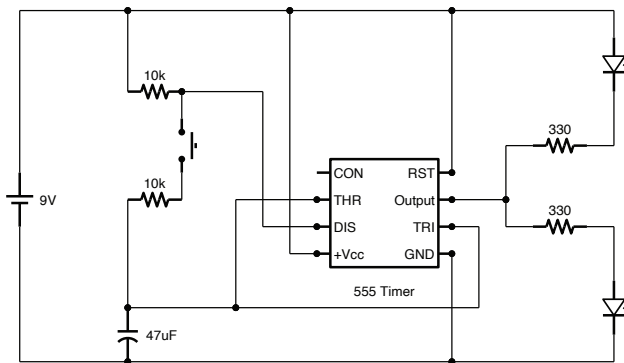

Materials:

- 1 3x7cm Circuit Board
- 2 Bridge Pins
- 2 2-Pin Female Bridges
- 2 U-bridge connectors
- 1 555 Timer IC
- 2 330r Resistors
- 2 10k Resistors
- 1 Push switch
- 1 47uF 25v capacitor
- 1 50cm assorted wires

Project: 555 LED Flip Flop Circuit

Client:

5mm Dot Grid

Designer: Scott A. Campbell

Builder:

Scale:

2:1